



Logo on metal box



Features

1. 2500kg loading capacity
2. 550mm Width 1150mm Length by fork overall Ergonomically designed handle
3. Height lowered 75mm height raised 190mm
4. 3-Position handle control - Raise, Lower, and Neutral
5. $\Phi 160$ mm Polyurethane steering wheels, $\Phi 70$ mm double polyurethane fork wheels
6. Reliable oil leak-proof hydraulic system
7. Durable frame by heavy duty design
8. Integrated hydraulic cylinder

Advantages

- Hand pallet truck series add reinforcing rid, increase the load strength, strong and durable.
- The main part oil pump adopts quality carbon steel precision casting, go through conditioning, pass pressure Mpa test,, no oil leakage, no deformation.
- Body is made of carbon structure steel punch forming, go through polishing and galvanized process. durable wear resistant, never fade.
- The core part of oil pump is from Europe , all piston rods are hard-chrome plated. Eradicate oil spill disadvantage, durable in use.



Logo on metal box

Main technical data

Articles/model	unit	TUF-SDC20	TUF-SDC25	TUF-SDC30			
Q Rated load	kg	2000	2500	3000			
Carrying wheel	mm	φ70/60	φ70/60	φ80/70	φ80/70		
Steering wheel	mm	φ160/50	φ160/50	φ180/50	φ180/50		
h Fork lowest height	mm	75	75	85	85		
h1 Max.fork height	mm	190	190	200	200		
H1 Overall height	mm	400/450					
H Overall height	mm	1185/1230					
h2×b Fork size	mm	55/160					
L Fork length	mm	1150/1220					
B Overall width	mm	550/685	540/685				
L1 Overall length	mm	1520/1590	1530/1600	1530/1600			
Net weight	kg	55/57.5 59.5/62	58.5/61 63.5/66	56.5/59 60/62.5	60.5/63 64.5/67	67.5/70 77/79.5	72.5/75 82/84.5

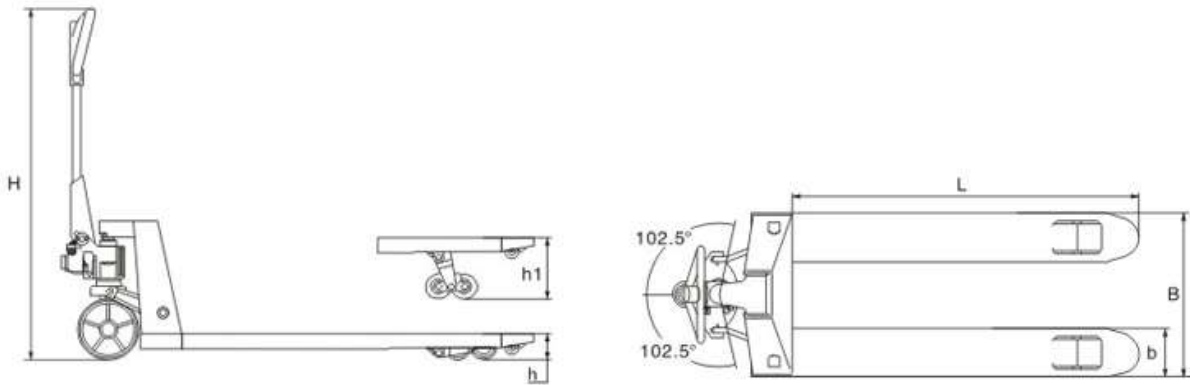



Logo on metal box



Single frame manual stacker is a kind of lifting handling and short-distance transportation tool. It has the following features: steady lifting, flexible moving, convenient operation. universal wheel has brake device, safe and reliable.

It has reasonable design, compact structure and good looking appearance, it's necessary tools for workshop, warehouse, wharf and station.

Liemke GmbH & Co. KG, Detmolder Str. 629 b, D-33699 Bielefeld, Germany
Tel: +49 (0)521 329 695 0 Fax: +49 (0)521 329



Logo on metal box

Main technical data

Articles/model	unit	TUF-CDSS10			TUF-CDSS15			TUF-CDSS20		
Q Rated load	kg	1000			1500			2000		
C Load center distance	mm				460					
Front wheel size	mm				φ80×70					
Steering wheel size	mm				φ180×50					
h Fork lowest height	mm				1600/2000/2500					
h1 Max.fork height	mm				2068/2568/3068					
L Fork length	mm				910(1150)					
T Fork adjustable width					320/680					
B Overall width	mm				1045					
L1 Overall length	mm				1585					
Turning radius	mm				1480					
V Distance between front and rear wheels	mm				1200					
Net weight	kg	253/267	286/300	306/302	264/278	306/320	336/350	271/285	316/330	346/360

